

# Electrochemical Trim & Cutoff Machine

## Affordable, Compact Burr-Free Production

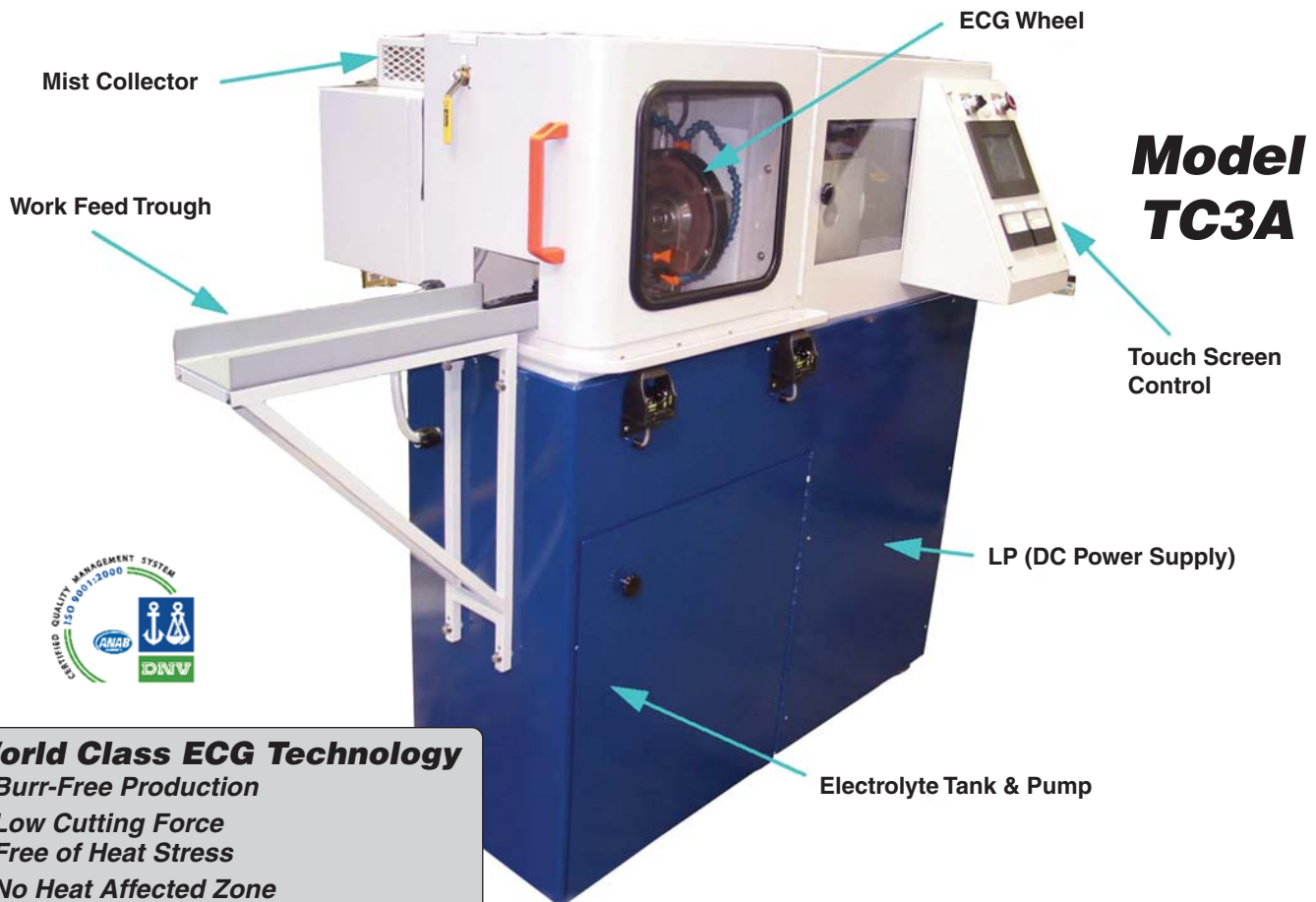

### World Class ECG Technology

- Burr-Free Production
- Low Cutting Force  
Free of Heat Stress
- No Heat Affected Zone
- No Work Hardening
- No Recast Layer
- No Metallurgical Damage
- Faster than EDM

### Cutoff Metals Independent of Hardness or Strength

- Harder than Rc 65
- Thin wall workpieces
- Thermosensitive materials

### Materials Include

- |             |             |              |
|-------------|-------------|--------------|
| • Stainless | • Inconel   | • Nitinol    |
| • Titanium  | • Hastelloy | • Tool Steel |
| • Carbide   | • Platinum  | • Stellite   |
| • Zirconium | • CoCr      | • Aluminum   |

## Model TC3A Electrochemical Trim & Cutoff Machine Capacity

- ECG Cutoff Wheel: 8.0" Diameter
- Workpiece Range: To 2-1/4" Diameter
- Cutoff Length: To 5" (With Standard Spindle Adapter)
- Spindle & Drive: 2 H.P. - Direct Drive
- Work Mount: 7-1/2" x 9-3/16"

### Ideal for Trim Cuts

- Bent Tubes
- Swaged Ends
- Cannula - Guide Wires - Catheters - Skive Tubes
- Bevel Cuts

**Everite Machine Products**  
501 E. Erie Avenue  
Philadelphia, PA 19134-1106  
TEL 215-425-3750  
FAX 215-426-7768  
e-mail: sales@everite.com

**Everite**  
MACHINE PRODUCTS CO.  
[www.everite.com](http://www.everite.com)

**Everite Europa**  
Eastway Business Park 1K, Unit 3  
Ballysimon Road, Limerick, Ireland  
TEL 011-353 61 415399  
FAX 011-353 61 468509  
e-mail: everite@iol.ie

# Electrochemical Trim & Cutoff Machine



## TC3A Floor Plan

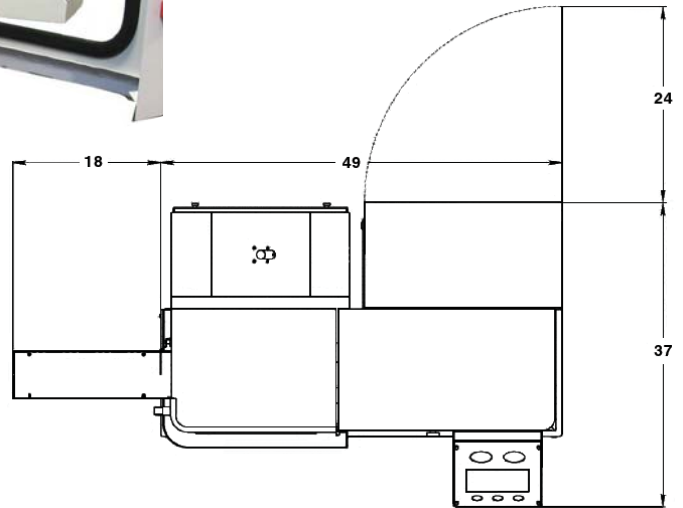

### Model TC3A Electrochemical Cutoff Machine

#### Specifications

<b>Capacity</b>	Range: to 2-1/4" Dia. Bar or Tube
<b>Cutoff Length</b>	5" Maximum (with standard wheel adapter)
<b>Electricals</b>	230/460 V / 3 PH / 60 Hz
<b>Wheel Diameter</b>	8" Diameter Maximum
<b>Spindle</b>	3200 RPM / 2 H.P. Direct Drive 150 Ampere Brush Rigging
<b>Cutting Speed</b>	0 to 25 In./Min.
<b>Rapid</b>	Approach & Return to 100 In./Min.
<b>LP</b>	150 Ampere DC Power Supply
<b>Pump</b>	230/460 3Ph 60 Hz 10 GPM
<b>Tank</b>	20 Gallon Electrolyte Tank
<b>Mist Collector</b>	350 CFM
<b>Color</b>	Everite Blue & Gray
<b>Water</b>	1/4" NPT (required for wash down)
<b>Machine Weight</b>	1,700 Lbs.
<b>Shipping Weight</b>	1,850 Lbs.

### Model TC3A Electrochemical Cutoff Machine

#### Standard Features

<b>Spindle Downfeed</b>	Power Feed
<b>Feed Rates</b>	0 - 25 In./Min
<b>Auto Cycle</b>	Rapid - Cut - Rapid Return
<b>Dress Cycle</b>	Wheel Rotation for Dress

#### Standard Equipment

<b>DC Power Supply</b>	Integrated 150 Amp. Lectropak
<b>Electrolyte</b>	20 Gal. Tank, Pump and Mist Collector
<b>Control</b>	Dual Palm Button Cycle Activation
<b>Cycles</b>	Auto Cycle and Dress Cycle
<b>Feed</b>	Powered Variable Speed Head
<b>Electrolyte Salts</b>	(1) Carton Formula 'ST'
<b>Manuals</b>	(1) Set of Manuals

### Everite . . . the one source for ECG

Electrochemical Sales • Service • Supplies  
Cutoff Machines • Surface Grinders • Point Grinders  
ECG Wheels: Conventional & Super-Abrasive  
Electrolyte  
Cutoff Fixtures: Standard & Custom

**Everite Machine Products**  
501 E. Erie Avenue  
Philadelphia, PA 19134-1106  
TEL 215-425-3750  
FAX 215-426-7768  
e-mail: sales@everite.com

**Everite**  
MACHINE PRODUCTS CO.  
[www.everite.com](http://www.everite.com)

**Everite Europa**  
Eastway Business Park 1K, Unit 3  
Ballysimon Road, Limerick, Ireland  
TEL 011-353 61 415399  
FAX 011-353 61 468509  
e-mail: everite@iol.ie